

University of Dundee

## Development of a series of 2D backfill ploughing physical models for pipelines and cables

Bizzotto, Tommaso; Brown, Michael; Brennan, Andrew; Powell, Toby; Chandler, Howard W.

*Published in:*  
Physical Modelling in Geotechnics

*Publication date:*  
2018

*Document Version*  
Peer reviewed version

[Link to publication in Discovery Research Portal](#)

### *Citation for published version (APA):*

Bizzotto, T., Brown, M., Brennan, A., Powell, T., & Chandler, H. W. (2018). Development of a series of 2D backfill ploughing physical models for pipelines and cables. In A. McNamara, S. Divall, & R. Goodey (Eds.), *Physical Modelling in Geotechnics: Proceedings of the 9th International Conference on Physical Modelling in Geotechnics (ICPMG 2018), July 17-20, 2018, London, United Kingdom* (1 ed., pp. 553-558). Taylor & Francis.

### **General rights**

Copyright and moral rights for the publications made accessible in Discovery Research Portal are retained by the authors and/or other copyright owners and it is a condition of accessing publications that users recognise and abide by the legal requirements associated with these rights.

- Users may download and print one copy of any publication from Discovery Research Portal for the purpose of private study or research.
- You may not further distribute the material or use it for any profit-making activity or commercial gain.
- You may freely distribute the URL identifying the publication in the public portal.

### **Take down policy**

If you believe that this document breaches copyright please contact us providing details, and we will remove access to the work immediately and investigate your claim.

# Development of a series of 2D backfill ploughing physical models for pipelines and cables.

T. Bizzotto, M. J. Brown, A. J. Brennan

*School of Science & Engineering, University of Dundee, Dundee, UK*

T. Powell

*Subsea7, Aberdeen, UK*

H. Chandler

*School of Engineering, University of Aberdeen, Aberdeen, UK*

Accepted Manuscript version of Development of a series of 2D backfill ploughing physical models for pipelines and cables, Bizzotto, T., Brown, M., Brennan, A., Powell, T. & Chandler, H. W., Jul 2018, Proc. 9th International Conference on Physical Modelling in Geotechnics (ICPMG 2018). 1 ed. Taylor & Francis, p. 553-558 4 p.  
<https://www.crcpress.com/Physical-Modelling-in-Geotechnics-Proceedings-of-the-9th-International-McNamara-Divall-Goodey-Taylor-Stallebrass-Panchal/p/book/9781138559752>

**ABSTRACT:** To investigate the process of pipeline/cable burial a pair of models has been developed to simulate a two-dimensional trench backfilling process at 1g, at two different length scaling ratios, 1:30 and 1:7.5. The aim is to investigate the influence of the velocity of the plough and the weight of the pipe or cable on its tendency to move during backfilling operations. Accelerometers attached to the model pipe ensure tracking of its position during the free motion of the pipe. The shape and velocity of the soil flow, down the slope of the trench, is monitored via particle image velocimetry (PIV) using the images from a MIRO R310 high-speed camera. The outcome of the tests will be to develop a framework to assess and quantify the risk of pipeline uplift and to improve design practice and certainty of meeting burial specifications.

## 1 INTRODUCTION

All offshore engineering is reliant on fast, safe, dependable and economically convenient connection between offshore and onshore facilities. Pipelines and cables usually require burial in order to protect them from mechanical damage and to improve the thermal insulation (Finch and Machin, 2001) for pipelines that transport high temperature product.

To minimize fabrication costs and ease material handling there is an obvious requirement to employ lighter materials with the restriction that the mechanical and thermal properties are met. Typically for pipelines the insulation is provided by a series of multi-layered coatings incorporating a layer of polymer foam (i.e. polypropylene, polyvinyl chloride, polyurethane) (Palmer and King, 2008), but if mechanical resistance is required to avoid the foam crushing due to hydrostatic pressure, a pipe in pipe scheme may be adopted. In such a solution the external pipe is designed to carry the mechanical and hydrostatic forces and the inner pipe carries the fluid. Both techniques rely on an increased diameter of pipe with much lighter materials, this leads to an overall decrease of the equivalent unit weight of the pipe (or specific gravity S.G.) because of the increase in cross-sectional area offset by a relatively minor increase in weight due to lower unit weight of the insulating material.

Burial of offshore pipelines and cables may be achieved through either jet trenching (Bizzotto, et al., 2017a; Bizzotto, et al., 2017b) or using a multiple phase trenching technique that involves the use

of different subsea tools. For instance, mechanical trenching ploughs may excavate a trench around the pipelines after they have been laid on the seabed (Lauder, et al., 2013; Lauder and Brown, 2014). Once the trench has been excavated (Figure 1), a backfill plough pushes the excavated soil back into the trench on top of the pipeline.

During the process of backfilling, pipelines or cables could move upward or unbury themselves by uplift due to the force generated by the soil flow impacting on the pipe or by buoyant flotation (Cathie, et al., 1998; Cathie, et al., 1996). To avoid overdesign of the unit weight of the pipeline/cable (in order to mitigate or prevent these issues), it is desirable to understand the forces acting on the objects and the processes that lead to upward movement of the pipelines and cables. The investigation of these type of processes must consider several phenomena, and a scaled series of models has been developed to take into account scaling effects. The aim of this study is to develop a test method to investigate the effect of the backfilling plough velocity on pipe/cables of different unit weights and monitor pipe displacements and imposed forces.

## 2 BACKFILL PLOUGHING 2D REPRESENTATION

According to Cathie, et al. (1998) the process may be represented as shown in Figure 2. If full spoil recovery is achieved the plough velocity should con-

vert into soil flow velocity down into the trench as represented in Figure 2.

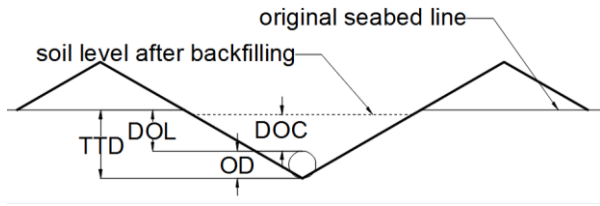

Figure 1. 2D schematic representation of a section of a post-lay ploughed trench, where TTD is target trench depth, DOL is depth of lowering, OD is the pipeline outer diameter and DOC is depth of cover after backfilling.

To simplify the modelling and allow a pipe/cable representation as large as possible it was decided to model the process as a 2D plane strain representation. The advantage of designing a 2D backfilling rig is that the same blade velocity in the model may be converted to different prototype plough velocities depending on the angle of attack of the blades (Fig. 3) using an approach based on the conservation of momentum as proposed by Kaku (1979). Once the process is represented in 2D, a plane strain model can be realized and the pipeline/cable can be represented by a cylindrical object with a stiffness that for the dimension of the model can be considered infinite. Therefore, any movement of the monitored pipe is due to rigid body motion of the object and not due to its deformation. This is important when considering the quantity of different pipe/cable products that are available (varying longitudinal bending stiffness), and that a 3D characterization of the process would be intrinsically dependent on the longitudinal bending stiffness of the model pipe/cable. In our case a 2D plane strain cylindrical object will be free to move and its movements monitored through the use of MEMs accelerometers.

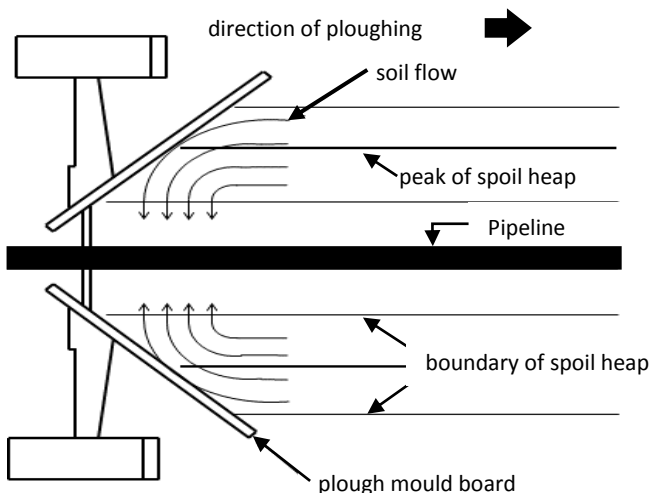

Figure 2. Schematic plan view of backfill ploughing process (redrawn from Cathie, et al. (1998))

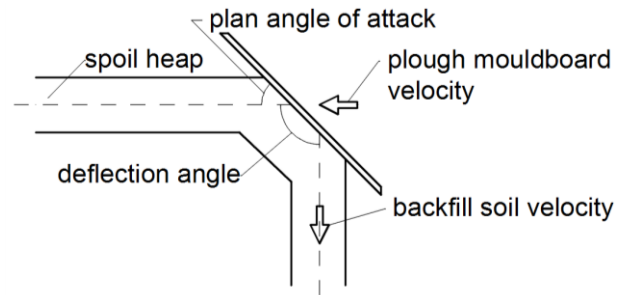

Figure 3. Schematic plan of one-blade backfilling for a conservation of momentum approach with a blade angle of attack of 45 degrees (redrawn from Kaku (1979))

### 3 PHYSICAL MODELLING OF SUBSEA BACKFILL PLOUGHING

To investigate the backfilling process, the forces acting on the pipeline/cables and eventual scaling issues, a pair of plough backfilling rigs have been designed and fabricated. The two approximate geometric scales are 1:30 (small scale) and 1:7.5 (large scale). The dimension of the tanks are 0.98 m x 0.48 m x 0.44 m (L x W x H) and 1.89 m x 1.05 m x 0.90 m (L x W x H) (Fig. 4) for the small and large scales respectively. Both the models have two plate sliders at the top of the tank to which the simple backfilling blades are attached (Fig. 5). The plates move on 4 linear bearings that move on two parallel hardened steel shafts (an adaptation of a model first developed at University of Dundee by Taylor (2011)). The small backfill model blades are actuated by a rotary motor which winds a steel wire on a spool mounted on the axis of the motor itself. The wire is directly attached to the first slider which carries the first blade, and the linear motion is reversed for the second blade through a pulley mounted on the other side of the box. The creation of the 1:7.5 model was a non-trivial problem, due to physical size and the large frictional and inertial forces that need to be overcome to backfill at higher velocities, hence the necessity of an adequate structural performance of the rig and actuator capacity. The larger scale model motion is provided by a hydraulic piston with a maximum capacity of 69kN. As with the smaller model, the actuator pushes one of the sliders (fig. 5) with the other connected by a wire that passes through a pulley to reverse the motion.

The maximum blades velocities that each scaled model can achieve are  $v_{\max\text{-small}}=0.16$  m/s and  $v_{\max\text{-large}}=0.095$  m/s for the small and the large scale models respectively. At present only one pipe diameter has been investigated for each scaled model (reported in Table 1) to be buried at a depth of cover (DOC) of 1.5 diameters. The

pipes can be ballasted and resealed to achieve different pipe unit weights similarly to that used by Bizzotto, et al. (2017b) in fluidized clay to investigate the influence of pipeline/cable unit weight on flotation potential.

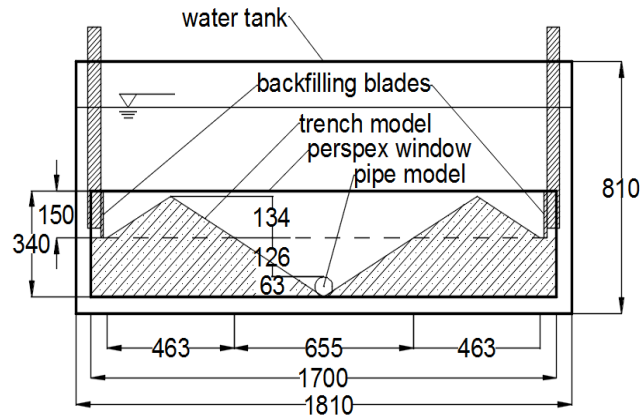

Figure 4. Schematic of large tank, scale 1:7.5 (All dimensions in mm, sliders and actuation not shown for clarity)

### 3.1 Water depth

The minimum depth of water required on top of the trench model that does not affect the flow of the soil is calculated based on the results for gravity currents from Gonzalez-Juez, et al. (2009). Assuming that the flow of soil does not exceed the initial height of the spoil heap a minimum height of water over the spoil heaps of at least 2 times the spoil heap height will be required. In the model, the height of water used was at least 3 times the spoil heap height for the large and small-scale models.

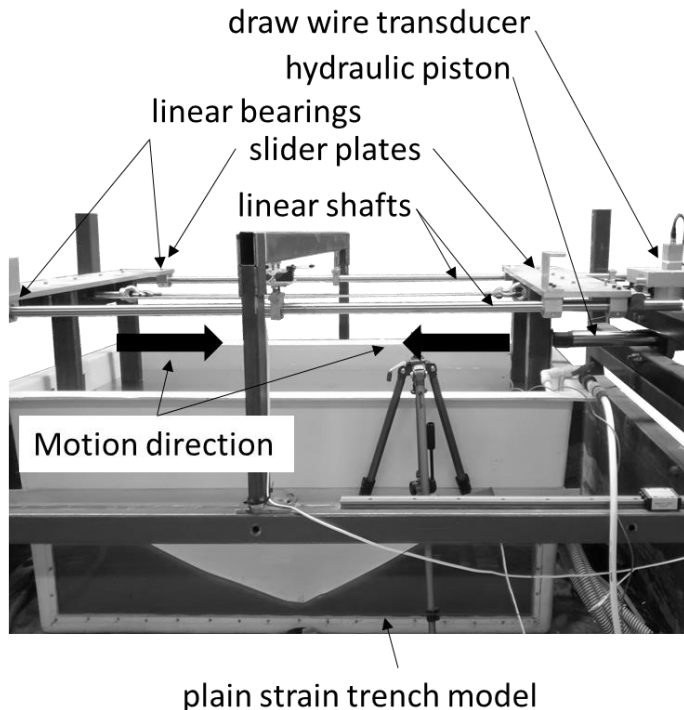

Figure 5. Model 1:7.5 2D backfilling rig actuation system.

Table 1. Pipe diameter and cover depth of soil over the pipe

	Scale	Pipe diameter mm	Depth of cover Diameters (mm)
Small scale test	1:30	16	1.5D (24)
large scale test	1.75	63	1.5D (95)*

\*parenthesis shows actual depth in mm

### 3.2 Instrumentation

The two models have been instrumented to measure the displacement of the blades using a 150mm linear variable displacement transducer (LVDT) from 'RDP LDC Series' and a 5m draw-wire transducer WS17KT-5000 from 'ASM Sensors', for the small and large models respectively. The free movement of the pipe is monitored via two dual-axes MEMs accelerometers placed at both ends of each pipe. The axes of the accelerometers are oriented to capture the acceleration on the 2D plane investigated in these set of tests. Figure 6 shows the orientations of the axis of the two accelerometers on a representative cylinder. The accelerometers are ADXL203CE micro electro-mechanical systems (MEMS). This kind of sensors use a combination of mechanical response of a two degree of freedom lumped-mass system and the sensing capacity due to the variable parallel plate capacitors that correlate the change in the capacity (C) and the displacement of the inertial mass as schematized in Figure 7.

The ADXL203CE has a  $\pm 1.7g$  range of accelerations on both axes. The pipe  $\beta$  angle (Fig. 6) and the accelerometers must be calibrated every time the accelerometers are removed from the pipes and re-attached. To achieve this the pipe is rolled around its longitudinal axis in a smooth and slow pure rotational motion, in this way only the gravitational acceleration is measured, and its decomposition on the accelerometer axes gives the angle to the horizontal  $\alpha_{1st}$  and  $\alpha_{2nd}$  (Fig. 6). From the difference of  $\alpha_{1st}$  and  $\alpha_{2nd}$  we get  $\beta$ .

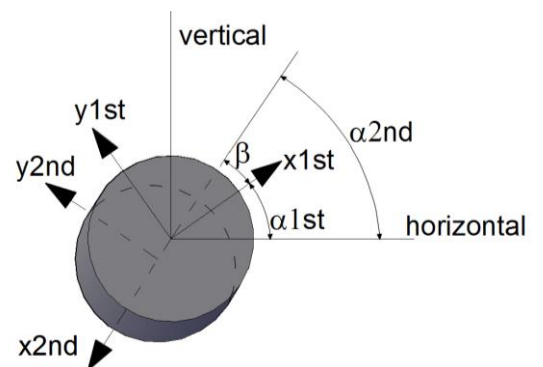

Figure 6. accelerometer axis representation. 1<sup>st</sup> represents the axis of the accelerometer near the front Perspex window and the 2<sup>nd</sup> is the accelerometer near the back wall.  $\beta$  is the out of phase angle between the two x axes of the front and back accelerometers.

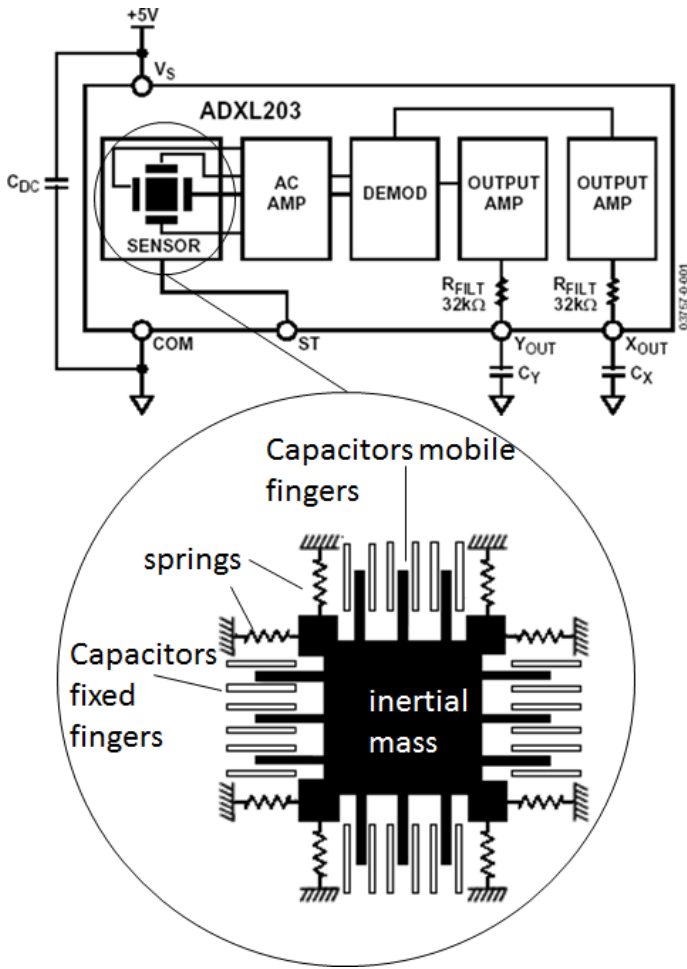

Figure 7. internal configuration of a MEMS accelerometer ADXL203CE, electronic and mechanical configuration, from Analog Devices (2006).

In Figure 8 and Figure 9 the accelerations during calibration are shown against time and against the back-calculated angle.

Both model tanks have a frontal Perspex window from which the model can be observed during back-filling. During the tests, the flow of the soil is recorded with a high-speed camera (Phantom MIRO R310). The camera can record a video of 3200fps (frames per seconds) at the maximum resolution of the camera, that is 1280x800 pixels (1Mpx), but this limits the time duration of the video that can be saved in the volatile buffer memory of the camera. For the testing the acquisition rate was set between 350fps and 700fps depending on the blade velocity. Once the event to be recorded ends, the image sequence can be saved in the embedded permanent memory of the camera or through an ethernet TCP/IP connection to a personal computer provided with the Phantom dedicated software. Various file formats are available for the image recordings, here a 12-bit TIFF file that allows for a lossless image storage was adopted.

The camera trigger is provided via a limit switch, connected to a pull up resistor, that is released once the blades are set in motion, this provides a falling edge signal as a differential TTL standard to the

camera. The camera trigger is recorded along with the other signals, in this way the image sequence can be synchronized with the data acquisition during the analysis of the data. Two set of lenses are used depending on the scale of the model, a Zeiss 25mm ZF.2 DISTAGON T\* for the 1:7.5 tests and a Zeiss 200mm ZF.2 MAKRO Planar for the 1:30 tests. For the large test model is only possible to record the video of only one slope of the trench (Fig.10a), for the small scale test the whole trench is recorded (Fig.10b). The data acquisition is performed with a national instrument DAQ USB 6211 with an acquisition rate of 20kHz at 16bit.

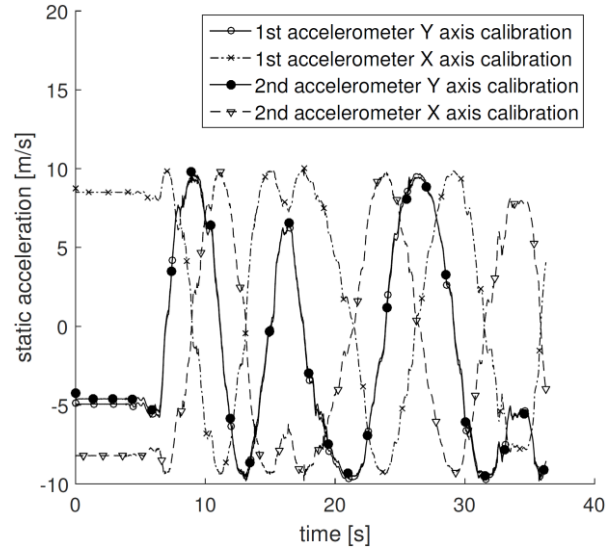

Figure 8. Accelerations measured during calibration by the front (1st) and the back (2nd) accelerometers.

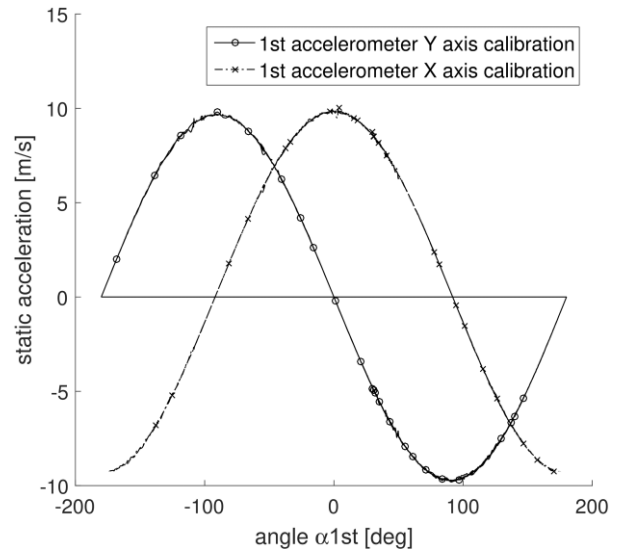

Figure 9. Accelerations from the 1st accelerometer plotted against the back-calculated angle  $\alpha.1st$ .

#### 4 DATA ANALYSIS

Both the accelerations and the video recordings need to be analysed. The accelerations require special treatment since the pipe is free to move vertically and horizontally, and it can rotate as well. If the rota-

tion of the pipe is not considered and assuming the angle  $\alpha_{1st}$  remain steady the acceleration analysed may be biased, i.e. accounting for an increase in vertical acceleration when the pipe has just rotated. In this case the x axis of the 1st accelerometer (front) would start to measure a proportion of the real horizontal acceleration as well as a decreased horizontal acceleration, but this is not a linear process and it would not auto-compensate. For this reason, it has been chosen to have 2 accelerometers, one on each side of the pipe. Accounting for the rotation of the two reference systems of the accelerometers (Equation 1) and resolving the system allow calculation of the angle  $\alpha_{1st}$  and  $\alpha_{2nd}$  during the test, when the pipe may be subjected to translational and rotational rigid body motion.

$$\begin{cases} accx_{pipe} = accx_{1st} \cos \alpha_{1st} - accy_{1st} \sin \alpha_{1st} \\ accx_{pipe} = -accx_{2nd} \cos \alpha_{2nd} + accy_{2nd} \sin \alpha_{2nd} \\ \alpha_{2nd} = \alpha_{1st} + \beta \end{cases} \quad (1)$$

The images recorded during the tests must be analysed as well, this can be done with the aid of a particle image velocimetry software, the one chosen is PivLab (Thielicke and Stamhuis, 2014) provided as an add-on to MATLAB software.

The soil particles act naturally as flow tracers and the images can be analysed directly as shown in Figure 11. The results of the PIV analysis can be used to infer the velocity of the soil impacting on the model pipe, on the strain rate of the soil while flowing down the trench and on possible scaling laws.

In Figure 11a series of images with the PIV velocity vectors superimposed can be seen. The results of the tests can be compared between the two geometric scaling ratios and at the different backfilling velocities.

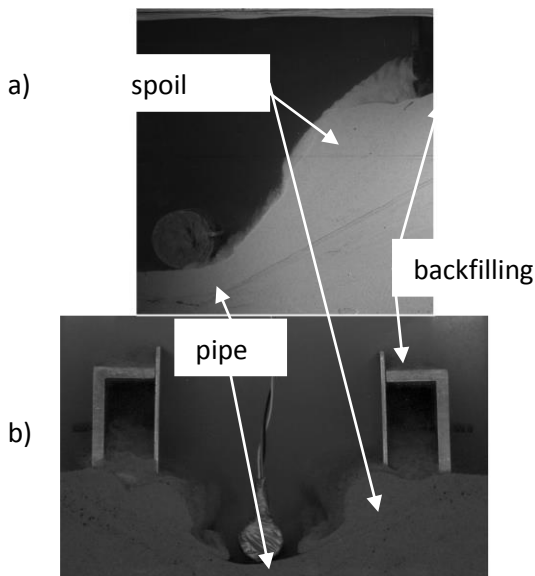

Figure 10. a) test image from 1:7.5 model; b) test image from 1:30 model. The soil used for the tests is a HST95 sand as in Lauder, et al. (2013).

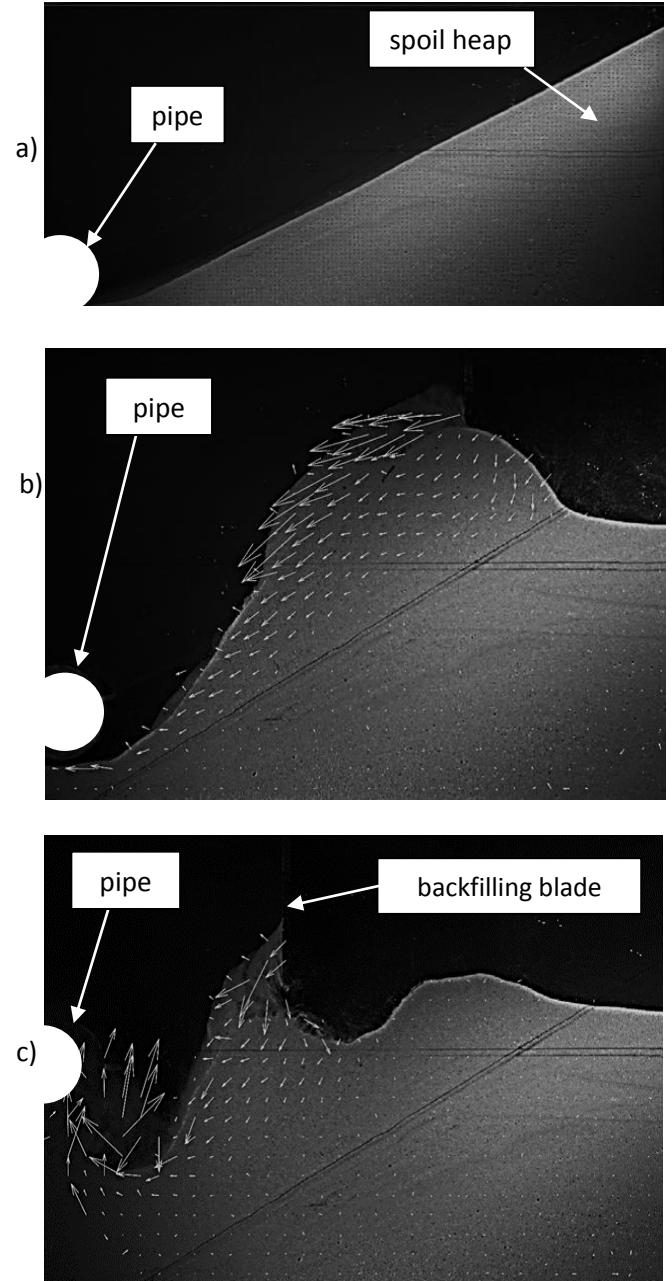

Figure 11. PIV results superimposed on the original images of a test with the large-scale model. The sequence shows the displaced pipe. a)  $t = 0$  s: initial frame for reference; b)  $t = 6.7$  s: the spoil heap is completely mobilized and the flow is starting to move downward; c)  $t = 9.8$  s: the soil flow has impacted on the pipe and is dragging it upward. The soil used for the tests is a HST95 sand as in Lauder, et al. (2013).

## 5 CONCLUSIONS

This article describes the background to recently developed backfilling simulation equipment at the University of Dundee. Two different scale systems have been developed at 1:7.5 and 1:30 for 2D representation of the pipeline/cable backfilling process.

The two scaled models are both provided with actuators capable of backfilling the trench at different velocities. This allows monitoring of the effect of the backfilling rate on the forces acting on the pipe.

The monitoring of blade displacements in the models is carried out with LVDT and DWT.

The monitoring of the forces acting on the pipe is achieved indirectly, measuring the acceleration of the pipe with known mass. The calibration of the accelerometer on the pipe and the data analysis has been proven to be of particular importance, especially when the pipe can rotate and translate, both horizontally and vertically during the test. An additional form of data capture is provided via a high-speed camera that records the tests, the images are subsequently analysed to measure the velocity and the strain rate of the soil particles.

The maximum backfilling velocities for the small and large models are  $v_{\max\text{-small}}=0.16$  m/s and  $v_{\max\text{-large}}=0.095$  m/s, and the test plan includes a parametric study on the velocity to understand the effect that it has on the forces exerted on the pipes and allow the consideration of scaling effects.

This research project aims to provide better insights into the industrial backfilling process, which is needed to improve the design process and optimise pipe/cable design and the speeds of installation. The design of lighter and cheaper pipelines and cables, is a key factor for faster development and cost reduction for both renewables energy and the oil & gas industries.

## 6 ACKNOWLEDGMENTS

The authors would like to acknowledge Subsea7 and the ETP Scotland (Energy Technology Partnership) for financial support and the European Regional Development Fund SMART lab at the University of Dundee for the facilities. John Anderson and Cameron Anderson that kindly provided technical knowledge and manufacturing insights.

## 7 BIBLIOGRAPHY

- Analog Devices, 2006. ADXL103/ADXL203 Datasheet. *Precision  $\pm 1.7g$  Single/Dual Axis Accelerometer*.
- Bizzotto, T., Brown, M.J., Powell, T., Brennan, A.J., & Chandler, H., 2017a. Modelling of pipeline and cable flotation conditions. In *Offshore Site Investigation and Geotechnics (OSIG)*. London, UK: Society for underwater technology, pp. 865–871.
- Bizzotto, T., Brown, M.J., Powell, T., Brennan, A.J., & Chandler, H., 2017b. Toward Less Conservative Flotation Criteria for Lightweight Cables and Pipelines. In *Twenty-seventh (2017) International Ocean and Polar Engineering Conference*. San Francisco, CA, USA, June 25-30, 2017: International Society of Offshore and Polar Engineers (ISOPE), pp. 535–540.
- Cathie, D.N., Barras, S., & Machin, J., 1998. Backfilling pipelines : State of the Art. *Offshore Pipeline Technology Conference, IBC*, p.29.
- Cathie, D.N., Machin, J.B., & Overy, R.F., 1996. Engineering

- appraisal of pipeline floatation during backfilling. In *Offshore Technology Conference*. pp. 197–206.
- Finch, M. & Machin, J.B., 2001. Meeting the Challenges of Deepwater Cable and Pipeline Burial. ID. OTC-13141-MS. *Offshore Technology Conference*.
- Gonzalez-Juez, E., Meiburg, E., & Constantinescu, G., 2009. Gravity currents impinging on bottom-mounted square cylinders: Flow fields and associated forces. *Journal of Fluid Mechanics*, 631, pp.65–102.
- Kaku, T., 1979. A study on the resistance of snowplowing and the running stability of a snow removal truck. *National Research Council (U.S.). Transportation Research Board.*, (185).
- Lauder, K.D., Brown, M.J., Bransby, M.F., & Boyes, S., 2013. The influence of incorporating a forecutter on the performance of offshore pipeline ploughs. *Applied Ocean Research*, 39, pp.121–130.
- Lauder, K.L. & Brown, M.J., 2014. Scaling effects in the 1 g modelling of offshore pipeline ploughs. In *8th Int. Conf. On Physical Modelling in Geotechnics ICPMG'14. 14-17th Jan 2014*. Perth, Western Australia: CRC Press, pp. 377–383.
- Palmer, A.C. & King, R.A., 2008. *Subsea Pipeline Engineering*, PennWell Books.
- Taylor, R., 2011. *Backfill - Pipeline Interaction*. MEng thesis. University of Dundee, UK.
- Thielicke, W. & Stamhuis, E., 2014. PIVlab—towards user-friendly, affordable and accurate digital particle image velocimetry in MATLAB. *Journal of Open Research Software*, 2(1), pp.1–10.