



University of Dundee

SpaceFibre Interfaces and Architectures

Parkes, Stephen; Ferrer Florit, Albert; Gonzalez-Villafranca, Alberto

Published in:
2019 IEEE Aerospace Conference

DOI:
[10.1109/AERO.2019.8741961](https://doi.org/10.1109/AERO.2019.8741961)

Publication date:
2019

Document Version
Peer reviewed version

[Link to publication in Discovery Research Portal](#)

Citation for published version (APA):

Parkes, S., Ferrer Florit, A., & Gonzalez-Villafranca, A. (2019). SpaceFibre Interfaces and Architectures. In *2019 IEEE Aerospace Conference* (pp. 1-8). [8741961] (IEEE Aerospace Conference Proceedings; Vol. 2019-March). IEEE. <https://doi.org/10.1109/AERO.2019.8741961>

General rights

Copyright and moral rights for the publications made accessible in Discovery Research Portal are retained by the authors and/or other copyright owners and it is a condition of accessing publications that users recognise and abide by the legal requirements associated with these rights.

- Users may download and print one copy of any publication from Discovery Research Portal for the purpose of private study or research.
- You may not further distribute the material or use it for any profit-making activity or commercial gain.
- You may freely distribute the URL identifying the publication in the public portal.

Take down policy

If you believe that this document breaches copyright please contact us providing details, and we will remove access to the work immediately and investigate your claim.

SpaceFibre Interfaces and Architectures

Steve Parkes
Space Technology Centre,
166 Nethergate,
University of Dundee,
Dundee, DD1 4HN, UK
+44 1382 225613
smparkes@dundee.ac.uk

Albert Ferrer Florit
STAR-Barcelona,
Av. Cerdanyola, 79-81
Planta 2, Oficina 2
08172 Sant Cugat del Vallès
Barcelona, Spain
+34 93 461 74 84
Albert.Ferrer@star-dundee.com

Alberto Gonzalez Villafranca
STAR-Barcelona,
Av. Cerdanyola, 79-81
Planta 2, Oficina 2
08172 Sant Cugat del Vallès
Barcelona, Spain
+34 93 461 74 84
Alberto.Gonzalez@star-dundee.com

Abstract - SpaceFibre is the next generation of SpaceWire network technology for spacecraft on-board data-handling. It runs over electrical or fibre-optic cables, operates at very high data rates, and provides in-built quality of service (QoS) and fault detection, isolation and recovery (FDIR) capabilities, providing high-reliability and high-availability. This paper provides an introduction to SpaceFibre and then describes how SpaceFibre can be used as an instrument interface, as the interface and memory interconnection network in a mass-memory unit, as the interface to a downlink transmitter and as the backplane for a payload processing unit. The paper also describes an overall payload processing architecture based on SpaceFibre and explains how existing SpaceWire equipment can be readily integrated into a SpaceFibre network.

Index Terms—SpaceWire, SpaceFibre, Network, SpaceVPX, VITA, Spacecraft On-board Data-Handling, FPGA, RTG4, Radiation Tolerant, Quality of Service, FDIR, Next Generation Interconnect.

TABLE OF CONTENTS

1. INTRODUCTION	1
2. SPACEFIBRE	1
3. SPACEFIBRE INSTRUMENT INTERFACE.....	3
4. SPACEFIBRE IN MASS MEMORY UNITS.....	4
5. SPACEFIBRE DOWNLINK INTERFACE.....	4
6. SPACEFIBRE IN PAYLOAD PROCESSING	5
7. SPACEFIBRE ONBOARD DATA-HANDLING NETWORK	5
8. CONCLUSIONS	7
ACKNOWLEDGMENTS	7
REFERENCES.....	7
BIOGRAPHIES.....	7

1. INTRODUCTION

SpaceFibre [1][2][3][4] is the next generation of SpaceWire [5][6] network technology for spacecraft on-board data-handling. It runs over electrical or fibre-optic cables, operates at very high data rates, and provides in-built quality of service

(QoS) and fault detection, isolation and recovery (FDIR) capabilities, providing high-reliability and high-availability.

This paper lists the main characteristics and capabilities of SpaceFibre and introduces some of the main concepts used in a SpaceFibre network. The architecture of a SpaceFibre instrument interface is then described and an example of a SpaceFibre camera provided. The use of SpaceFibre in a mass memory unit is then considered and the interface architecture for a downlink transmitter described. A payload processing system is explored which uses SpaceFibre as a backplane connecting dual-redundant system controllers and payload processing modules together. Based on SpaceVPX, the use of SpaceFibre enhances reliability and reduces the backplane pin count. Finally, an example spacecraft onboard data-handling architecture is outlined, explaining how the various elements communicate with one another over a SpaceFibre network.

2. SPACEFIBRE

The main characteristics of SpaceFibre will now be summarised and SpaceFibre networks, links, lanes and virtual channels described.

SpaceFibre Characteristics and Capabilities

The main characteristics and capabilities of SpaceFibre are summarised below:

- Very high-performance with 3.125 Gbps single-lane performance (including overhead for 8B/10B encoding) in current radiation tolerant FPGAs, 12.5 Gbps with four lanes, and substantially high data rates planned in future devices.
- Electrical and Fibre Optic media with the electrical medium supporting cable lengths up to 5 m, depending on data rate, and fibre optics supporting up to 100 m.
- High reliability and high availability using error-handling technology which is able to recover automatically from transient errors in a few microseconds without loss of information and which is

able to continue operation, preserving data transfer of critical and important information, when a lane in a multi-lane link fails.

- Quality of service using multiple virtual channels across a data link, each of which is provided with a priority level, a bandwidth allocation and a schedule.
- Virtual networks that provide multiple independent traffic flows on a single physical network, which, when mapped to a virtual channel, acquire the quality of service of that virtual channel.
- Deterministic data delivery of information using the scheduled quality of service, in conjunction with priority and bandwidth allocation.
- Low-latency broadcast messages which provide time-distribution, synchronisation, event signalling, error reporting and network control capabilities.
- Small footprint which enables a complete SpaceFibre interface to be implemented in a radiation tolerant FPGA, for example, around 3% of an RTG4 FPGA for an interface with two virtual channels.
- Backwards compatibility with SpaceWire at the network level, which allows simple interconnection of existing SpaceWire equipment to a SpaceFibre link or network.

SpaceFibre Links and Networks

A SpaceFibre network is made up of nodes, routing switches and links that connect the nodes and routing switches together. The nodes are the units that use the services of SpaceFibre including instruments, mass-memory units, payload processors, etc. These nodes can be connected together directly with a SpaceFibre link, for example an instrument being connected directly to a mass-memory unit. Alternatively, the nodes can be connected via a routing switch. When several nodes are all connected to a routing switch those nodes can all communicate with each other via the routing switch. A SpaceFibre packet includes an address at the start of the packet which determines how that packet is routed through the network.

SpaceFibre Virtual Channels

A SpaceFibre link is bi-directional and carries one or more virtual channels over the link. There is a SpaceFibre interface at each end of the link, either in a node or in a routing switch. A SpaceFibre interface includes a number of virtual channels. Each virtual channel provides a FIFO type interface similar to that of a SpaceWire link. When data from a SpaceFibre packet is placed in a SpaceFibre virtual channel it is transferred over the SpaceFibre link and placed in the same numbered virtual channel at the other end of the link. Data from the several virtual channels are interleaved over the physical SpaceFibre connection. A virtual channel can be assigned a quality of service which determines the precedence with which that virtual channel will compete with other virtual channels for sending data over the SpaceFibre link. Priority, bandwidth

reservation, and scheduled qualities of service can be supported, all operating together using a simple precedence mechanism.

To provide quality of service, it is necessary to be able to interleave different data flows over a data link or network. If a large packet is being sent with low priority and a higher priority one requests to be sent, it must be possible to suspend sending the low priority packet and start sending the higher priority packet. To support the interleaving, packets are chopped up and sent in short frames of up to 256 SpaceFibre N-chars each. An N-Char is a data byte, End of Packet marker (EOP) or Error End of Packet marker (EEP). When the high priority packet requests to be sent, the current frame of the low priority packet is allowed to complete transmission, and then the frames of the high priority packet are sent. When all the frames of the high priority packet have been sent, the remaining frames of the low priority packet can be sent. Each frame has to be identified as belonging to a particular data flow so that the stream of packets can be reconstructed at the other end of the link.

Each independent data stream allowed to flow over a data link is referred to as a virtual channel (VC). Virtual channels are unidirectional and have a QoS attribute. The QoS attributes are priority, allocated bandwidth and schedule. Together these attributes determine the precedence of a virtual channel. If one virtual channel exceeds its allocated bandwidth, the precedence of that virtual channel is automatically reduced so that its use of link bandwidth is constrained and it cannot adversely affect the traffic in other virtual channels.

SpaceFibre Lanes

The multi-laning capabilities of the SpaceFibre protocol [7] allow several lanes to operate in parallel to provide enhanced throughput. For example, with four lanes each running at 2.5 Gbits/s an aggregate throughput of 10 Gbits/s is achieved. SpaceFibre multi-laning can operate with any number of lanes, from 1 to 16. Each lane is normally bi-directional, but to support spaceflight instruments with very high-data rate in one direction and to save mass and power, it is possible to have some uni-directional lanes in a multi-lane link, provided that at least one lane is bi-directional. SpaceFibre multi-laning also supports graceful degradation in the event of a lane failure. If a lane fails, the multi-lane link will rapidly reconfigure to use the remaining lanes so that important (high priority) information can still get through. It takes a couple of microseconds for this reconfiguration to occur, which happens without loss of information. Clearly, with reduced bandwidth some information will not be sent over the link, but this will be less important, low priority, information. If a redundant lane is available in the link, it can be enabled and full capacity operation will resume.

3. SPACEFIBRE INSTRUMENT INTERFACE

Instrument Interface

An instrument interface is straightforward to design with SpaceFibre. The primary data from the instrument can be allocated to one virtual channel, while configuration and control commands and housekeeping data can be allocated to a separate virtual channel. There is then no need for a separate control bus, improving reliability and reducing mass and power consumption. A single-lane interface can be used for moderate data rate instruments and this can be replaced by a multi-lane link for higher data rate instruments, the number of lanes being matched to the instrument data rate. Additional lanes can be added, when the instrument data is critical, to provide hot or cold lane redundancy, allowing rapid recovery in the event of a lane failure. Nominal and redundant interfaces can be added to the instrument, with support for autonomous redundancy switching if required.

A typical SpaceFibre instrument interface is illustrated in Figure 1.

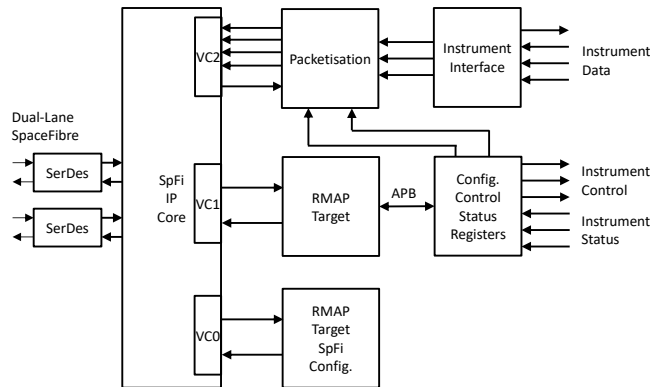

Figure 1: Dual-Lane SpaceFibre Instrument Interface

The main part of the SpaceFibre interface is implemented using a SpaceFibre IP core which connects to one or more SerDes to provide the interface to the SpaceFibre link. In Figure 1 there are two SerDes providing a dual-lane SpaceFibre interface. One or more virtual channel interfaces provide the connection to the instrument. Virtual channel VC0 is used for network configuration, control and monitoring and provides access to the control and status registers of the SpaceFibre IP core using the Remote Memory Access Protocol (RMAP) [8]. VC1 is also connected to an RMAP target which is used to access the configuration, control and status registers of the instrument. It is possible to use VC0 to access both SpaceFibre network and equipment configuration spaces, but in the instrument interface of Figure 1 these two functions operate over separate virtual channels. VC2 provides the data interface for the instrument. Data is passed from the instrument electronics to SpaceFibre via a parallel FIFO type interface. The data is packetized by adding an address at the start of the packet and an end of packet marker (EOP) at the end. The packet can hold the data in a way that

suits the application. For example, a multispectral image sensor can put each image row in its own packet, or each spectral-band image in a packet, or the entire set of data for each image in one packet. It is up to the application.

SpaceFibre Camera

STAR-Dundee has developed a SpaceFibre camera which provides high-resolution and high frame-rates [9]. It is suitable for both Earth Observation, vision-based navigation and robotic applications. The camera incorporates a Microsemi RTG4 FPGA [10][11] which, as well as providing the image sensor interface, control logic and SpaceFibre interfaces, has plenty of room left for data compression or other image processing applications to be integrated in the camera. One specific example is image feature extraction and tracking for the vision-based navigation of planetary landers. A block diagram of the SpaceFibre Camera is provided in Figure 2.

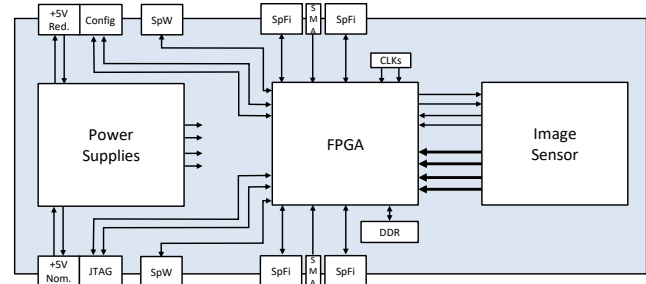

Figure 2: SpaceFibre Camera Block Diagram

There are ten connectors on the SpaceFibre camera: four SpaceFibre connectors (2-lane nominal and 2-lane redundant), two SMA trigger input connectors, two SpaceWire connectors (nominal and redundant) and +5V DC power connectors (nominal plus JTAG and redundant plus configuration).

The image sensor is configured and controlled by an FPGA. The image sensor sends image data to the FPGA via 16 LVDS differential pairs running at up to 480 Mbits/s per pair. The FPGA includes four SpaceFibre lanes which can operate as two 2-lane links or one 4-lane link. When operating with two 2-lane links, one is active and the other is redundant. The FPGA transfers the image data out of the camera over the active SpaceFibre link. There are also two SpaceWire interfaces (nominal and redundant) which can be used for transferring data instead of using the SpaceFibre interfaces.

Camera configuration, control and housekeeping requests are received over virtual channel 0 of the active SpaceFibre link or over the active SpaceWire link when in SpaceWire interface mode. The FPGA interprets these commands and transfers information to and from the image sensor accordingly, using the control interface of the image sensor.

Attached to the image sensor is a bank of EDAC protected DDR memory which can be used to store images when the FPGA is being used as an image processor.

A photograph of the SpaceFibre Camera is shown in Figure 3.



Figure 3: SpaceFibre Camera

4. SPACEFIBRE IN MASS MEMORY UNITS

SpaceFibre can be used to provide both the interface to a mass-memory unit and the high-data rate network for interconnecting memory modules. Virtual channels can be used to separate different classes of traffic within the memory system, for example, data to be stored, data to be retrieved and control and housekeeping information. A SpaceFibre interface to a mass memory unit is illustrated in Figure 4.

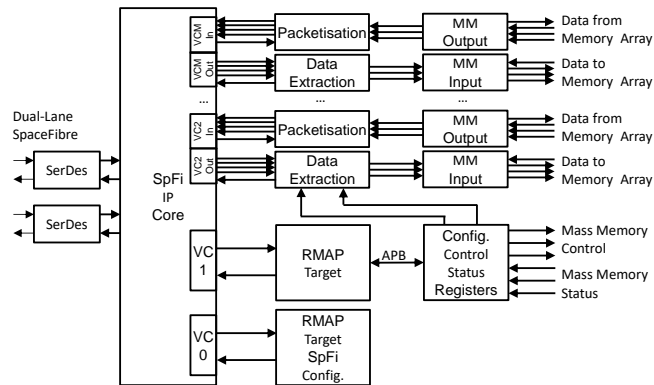

Figure 4: Dual-Lane SpaceFibre Mass-Memory Interface

The SpaceFibre interface can use multiple lanes to support the required data rates into the mass memory. The main instruments can be assigned their own virtual networks which are mapped to the virtual channels in the mass memory interface. The traffic from these instruments is then assigned a bandwidth allocation for its virtual network and it is then guaranteed to have that bandwidth on the physical SpaceFibre network. Other instruments, for example legacy instruments with SpaceWire interfaces, can be connected together to a single virtual network. In this case the packets from each instrument are multiplexed one after the other on to the virtual network. The bandwidth allocated to that virtual network is the aggregate bandwidth for all the instruments connected to it.

In Figure 4 there are several virtual networks. Data arriving from the instruments in SpaceFibre packets is extracted from

those packets and passed to the memory array for storage. The memory array may be formed from several memory modules interconnected by a SpaceFibre network, in which case the data arriving on the external SpaceFibre network is repackaged for sending to the appropriate memory modules.

The external SpaceFibre links of the mass memory unit can also be used for passing data from the mass memory unit to the downlink transmitter or to a payload data processor or data compression unit. The data read from the memory array is encapsulated in SpaceFibre packets with appropriate addresses to send them to the required destinations.

A prototype mass memory system developed by Airbus GmbH, STAR-Dundee and IDA is shown in Figure 5 [12].

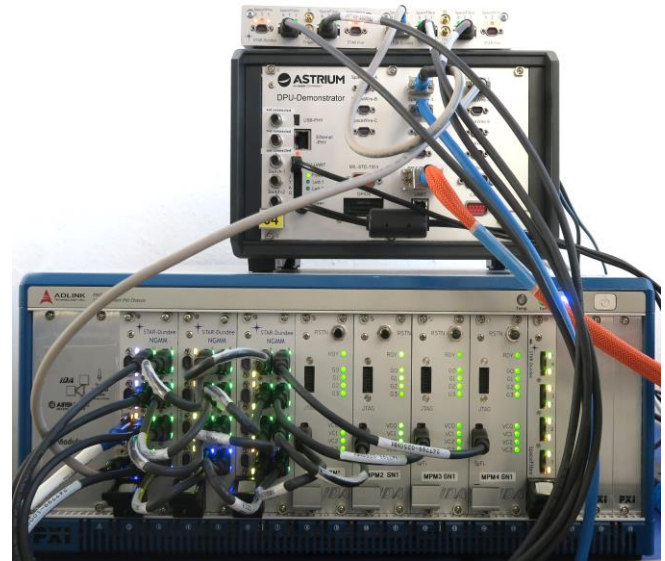

Figure 5: Prototype Next Generation Mass Memory System

Starting on the left of the rack at the bottom of the photograph there are the following boards:

- External SpaceFibre and SpaceWire interface board
- Two SpaceFibre routing switches forming a SpaceFibre network inside the mass memory unit
- Four memory modules attached to the SpaceFibre network

On the top of the photograph is a computer that controls the mass memory operation, which is connected into the internal SpaceFibre network by a SpaceWire link.

5. SPACEFIBRE DOWNLINK INTERFACE

A SpaceFibre interface to a downlink transmitter is illustrated in Figure 6.

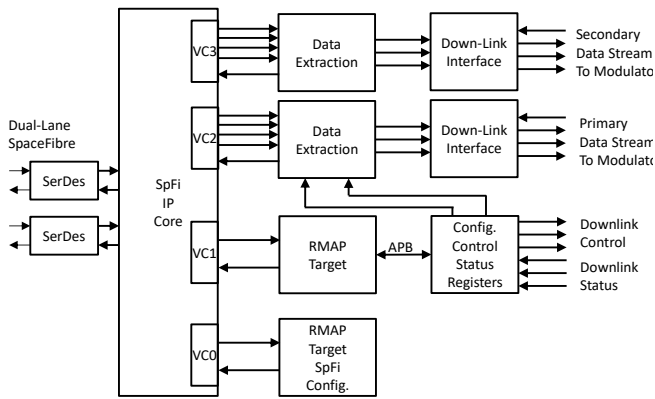

Figure 6: Dual-Lane SpaceFibre Downlink Interface

The SpaceFibre IP core, SerDes, RMAP target on VC0 for network control and RMAP target on VC1 for equipment control are identical to that of the SpaceFibre instrument interface of Figure 1. There are two other virtual channels, VC2 and VC3, which supply the data to be sent over the downlink. VC2 is providing the primary data source and VC3 is providing a secondary data source. It is possible to use a single virtual channel or more than two depending on the application requirements. Normally the downlink is connected to the mass-memory unit which determines the flow of data to the downlink. Having two virtual channels supporting two streams allows a direct broadcast instrument to send data concurrently with data from the mass-memory.

6. SPACEFIBRE IN PAYLOAD PROCESSING

There is a growing need for a standard electronics backplane for spacecraft on-board processing systems to help reduce development costs, timescales and schedule risk, and to increase the reuse of proven components. Standard backplane racks are widely used in commercial, industrial and military applications, but spacecraft electronics tend to be bespoke, owing to the severe environment and mass and size constraints. The primary issue with operation in the space environment is the general lack of serviceability and the resulting need for the system to operate reliably for many years. It must be possible to recover from any single fault on a spacecraft and to prevent a fault from propagating to other parts of the spacecraft systems. SpaceVPX [13] is a new development in the area of standard backplanes for spacecraft applications, which addresses the key issue of fault tolerance. SpaceFibre has been designed into SpaceVPX standard as a backplane communication medium.

SpaceVPX uses several physical planes (data plane, control plane and utility/management plane) to separate different classes of backplane traffic, to avoid one class interfering with another class. Using SpaceFibre, these different planes can be run over separate virtual channels on a single physical network. This improves reliability and reduces mass and power consumption. It also frees up pins on the backplane. A new development within SpaceVPX is exploring the use of

SpaceFibre virtual planes. The proposed backplane arrangement is illustrated in Figure 7.

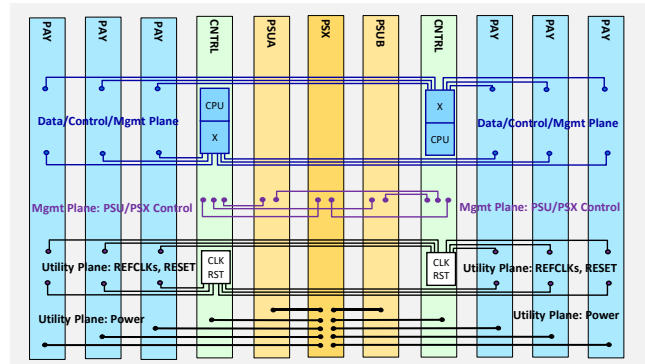

Figure 7: Proposed SpaceFibreVPX Backplane

All of the system controller to payload module and payload module to payload module communications is via a pair of SpaceFibre networks; one from the nominal and one from the redundant system controller. A SpaceFibre routing switch is incorporated in each system controller module to provide fast and flexible communication. The SpaceFibre links on the backplane are all dual-lane links. This provides reasonable backplane performance; 5 Gbit/s for a backplane running at 3.125 Gbit/s per lane, which is already five times faster than a 33-bit 33MHz PCI bus. The aggregate performance of the network is actually much higher; x2 for each direction of the link and x6 for the number of links resulting in 60 Gbit/s, 60 times faster than the PCI bus. Of course, with higher-speed SerDes the performance is even higher; 120 Gbit/s with 6.25 Gbit/s SerDes.

Importantly, the dual-lane links provide graceful degradation in the event of a link failure. This means that if one lane fails, it takes a few microseconds for the link to detect the error and continue operation as a single-lane link. The unit remains functional, albeit with reduced link bandwidth. Crucially, the management and control information can still be transferred over the link, allowing a controlled recovery from the fault.

The broadcast message capability of SpaceFibre can be used to distribute the timing signals and interrupts that are carried over the AUX_CLK signals in SpaceVPX. SpaceFibre can carry a wide range of time distribution, synchronisation, event signalling and fault notification information, and it does this while saving the pins that would otherwise have been used for AUX_CLK.

7. SPACEFIBRE ONBOARD DATA-HANDLING NETWORK

The overall payload processing and instrument control and monitoring network is straightforward to design with SpaceFibre. For many requirements a single SpaceFibre routing switch is all that is required, or two when nominal and redundant networks are required. When a single routing

switch does not provide enough interfaces, two or more routing switches can be cascaded to provide the required number of interfaces. This network can also distribute time information, pulse-per-second signals, event signals and network health status information.

An example SpaceFibre payload data handling network is illustrated in Figure 8.

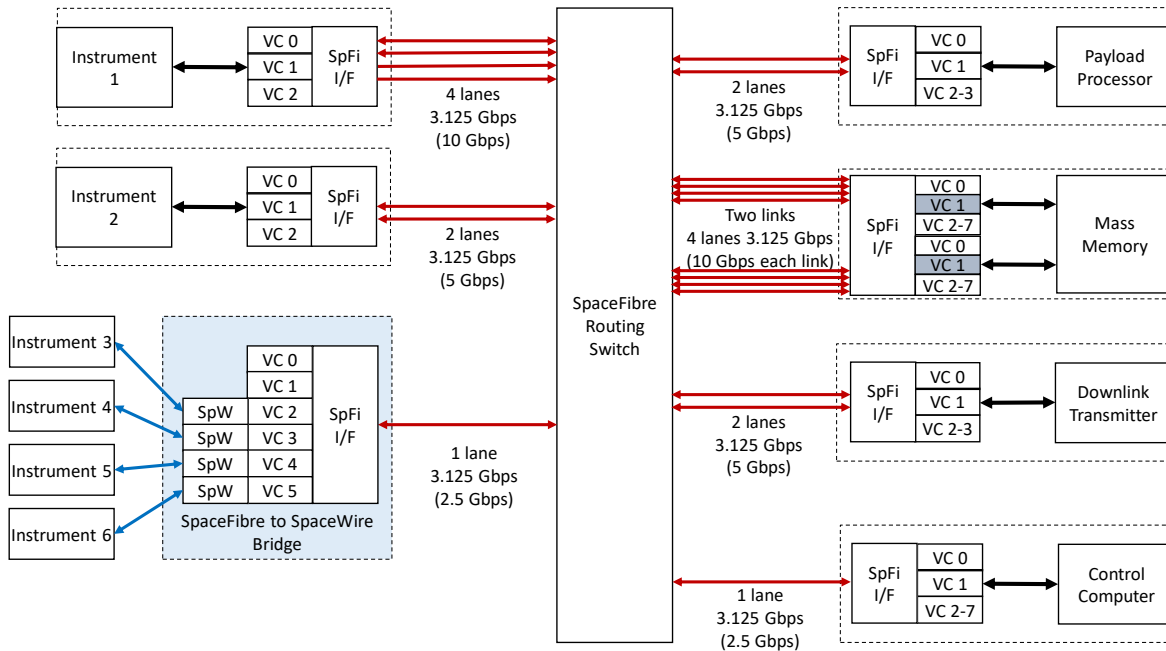

Figure 8: Example SpaceFibre Payload Data-Handling Network

The SpaceFibre routing switch has eight ports, with various numbers of lanes. All lanes throughout the network operate at 3.125 Gbit/s, including 8B10B encoding, giving a data rate per lane of around 2.5 Gbit/s. There are two high data-rate instruments; Instrument 1 which requires four lanes and Instrument 2 which requires two lanes. Each of these instruments has three virtual channels with VC0 being used for network control and VC1 for instrument control. The SpaceFibre routing switch maps the virtual channels to virtual networks, so that, for example, Instrument 1 VC 2 (the virtual channel used for the main data from the instrument) is mapped to virtual network 2 (VN2) and Instrument 2 VC2 is mapped to VN3.

There are four instruments with SpaceWire interfaces that are connected to a SpaceWire to SpaceFibre bridge. Each SpaceWire interface in this example is connected to a separate SpaceFibre virtual channel. The SpaceFibre routing switch maps them to separate virtual networks (e.g. VN3 to VN6). It is also possible for the SpaceWire interfaces to be connected all to the same virtual channel and hence to one virtual network.

The mass-memory unit has two SpaceFibre interfaces with four lanes each. Together they are able to provide a data rate of up to 20 Gbit/s into the mass memory unit. The downlink transmitter has a dual-lane SpaceFibre interface supporting data rates of up to 5 Gbit/s. VC2 and VC3 are used for the data

being streamed to the downlink. A payload data processing system is also included in the network again with two virtual channels used for data transfer.

A control computer is connected to the network using a single-lane SpaceFibre interface. It provides both network management and equipment management services. Network management commands and responses travel over VC0 mapped to VN0, and equipment management commands and responses travel over VC1 mapped to VN1. Through the network the control computer is able to configure control and monitor all of the equipment attached to the network. To send commands to the SpaceWire instruments additional virtual channels are required on the control computer which are mapped to the virtual networks being used by the SpaceWire instruments. If the SpaceWire instruments are all mapped to a single virtual network, the control computer can access them all with a single virtual channel.

The architecture and implementation of a SpaceFibre routing switch is described in [14] and [15].

To provide a redundant network a second routing switch is used connected to all of the equipment with a second set of SpaceFibre links from each unit.

8. CONCLUSIONS

The architecture of a SpaceFibre based onboard data-handling network based on a SpaceFibre routing switch has been outlined and the SpaceFibre interfaces to the data-handling elements have been described. STAR-Dundee has a complete range of SpaceFibre IP cores available: SpaceFibre single-lane and multi-lane interfaces, SpaceFibre routing switch and SpaceWire to SpaceFibre bridge. Using these IP cores it is straightforward to construct a very high performance, high reliability and high availability network for spacecraft payload data-handling applications.

ACKNOWLEDGMENTS

The research leading to these results has received funding from the European Space Agency under ESA contract numbers 4000102641 and 17938/03/NL/LvH, from the European Union Seventh Framework Programme (FP7/2007-2013) under grant agreement numbers 263148 and 284389, and from the UK Space Agency and CEOI-ST under University of Leicester contract numbers: RP10G0348A02, RP10G0348B206 and RP10G0348A207. Recently it has received funding from the European Union's Horizon 2020 research and innovation programme under grant agreement No 776151.

REFERENCES

- [1] ECSS Standard ECSS-E-ST-50-11C, "SpaceFibre", Issue 1, European Cooperation for Space Data Standardization, to be published and made available from <http://www.ecss.nl>.
- [2] S. Parkes, C. McClements and M. Suess, "SpaceFibre", International SpaceWire Conference, St Petersburg, Russia, 2010, ISBN 978-0-9557196-2-2, pp 41-45.
- [3] S. Parkes, A. Ferrer, A. Gonzalez, & C. McClements, "SpaceFibre: Multiple Gbits/s Network Technology with QoS, FDIR and SpaceWire Packet Transfer Capabilities", International SpaceWire Conference, Gothenburg, June 2013.
- [4] S. Parkes et al, "SpaceFibre: Multi-Gigabit/s Interconnect for Spacecraft On-board Data Handling", IEEE Aerospace Conference, Big Sky, Montana, 2015.
- [5] ECSS Standard ECSS-E-ST-50-12C, "SpaceWire, Links, Nodes, Routers and Networks", Issue 1, European Cooperation for Space Data Standardization, July 2008, available from <http://www.ecss.nl>.
- [6] S. Parkes, "SpaceWire User's Guide", ISBN: 978-0-9573408-0-0, STAR-Dundee, 2012, available from <https://www.star-dundee.com/knowledge-base/spacewire-users-guide> <https://www.star-dundee.com/knowledge-base/spacewire-users-guide> (last visited 12th Oct 2018).
- [7] A. Ferrer Florit, A. Gonzalez Villafranca and S. Parkes, "SpaceFibre Multi-Lane", International SpaceWire Conference, Yokohama, Japan, 2016, ISBN 978-0-9954530-0-5.
- [8] ECSS Standard ECSS-E-ST-50-52C, "SpaceWire – Remote memory access protocol", Issue 1, European Cooperation for Space Data Standardization, 5 February 2010, available from <http://www.ecss.nl>.

- [9] S. Parkes et al, "SpaceFibre Camera", International SpaceWire Conference, Long Beach, California, 2016.
- [10] Microsemi, "RTG4 FPGAs - High-Speed RT FPGAs for Signal Processing Applications", <http://www.microsemi.com/products/fpga-soc/radtolerant-fpgas/rtg4> (last visited 12th Oct 2018).
- [11] S. Parkes et al, "SpaceWire and SpaceFibre on the Microsemi RTG4 FPGA", IEEE Aerospace Conference, Big Sky, Montana, 2016.
- [12] Airbus, IDA, UoD "Next Generation Mass Memory Architecture (NGMMA) Summary Report", Report No. NGMMA-RP-0034, ESTEC Contract No. 22530/09/NULvH, 12th January 2018.
- [13] VITA, "SpaceVPX System", ANSI/VITA 78.00-2015, April 2015.
- [14] S. Parkes et al, "SpaceFibre Network and Routing Switch", IEEE Aerospace Conference, Big Sky, Montana, 2017.
- [15] S. Parkes et al, "SpaceFibre Networks", International SpaceWire Conference, Yokohama, Japan, 2016, ISBN 978-0-9954530-0-5.

BIOGRAPHIES



Steve Parkes is the Director of the Space Technology Centre at the University of Dundee leading research on spacecraft on-board data-handling networks (SpaceWire and SpaceFibre), planet surface simulation, autonomous lander navigation, and digital signal and image processing for satellites. Steve wrote the ECSS-E-ST-50-12C SpaceWire standard, the ECSS-E-ST-50-51C RMAP standard and the ECSS-E-ST-11C SpaceFibre standard with inputs from international spacecraft engineers. SpaceWire is now being used on more than 100 spacecraft, many of these also use RMAP. SpaceFibre is being designed into its first systems and ASICs. Steve is currently researching deterministic networks for integrated avionics and payload networks, higher layer protocols for SpaceFibre, vision-based navigation for planetary landers, and FFT-based spectrometers for an atmospheric chemistry instrument.



Albert Ferrer-Florit has a PhD in high-speed interconnection networks for space applications awarded by the University of Dundee. His PhD research was funded by ESA's Networking/Partnering Initiative after he worked in the on-board data processing group (TEC-EDP) in ESTEC. He is specialised in SpaceWire and SpaceFibre networks, being one of the key developers of the SpaceFibre standard. He started his career at CERN in the Summer Student Programme, worked for STAR-Dundee and is currently working for STAR-Barcelona as a Network and Systems Engineer.



Alberto Gonzalez Villafranca holds a doctorate in data compression for space applications and has been connected to the space field his entire professional career. Alberto has been deeply involved in the definition and implementation of SpaceFibre since he joined STAR-

Dundee Ltd. Before working with SpaceFibre he had collaborated with the Gaia mission and worked on a hardware implementation of a deterministic variant of the SpaceWire protocol at the European Space Agency. Alberto is now working for STAR-Barcelona.